

Installation / Maintenance

Neutralizer® AC

Emitter Pin Replacement

Model 6500

Replace the emitter pin as follows:

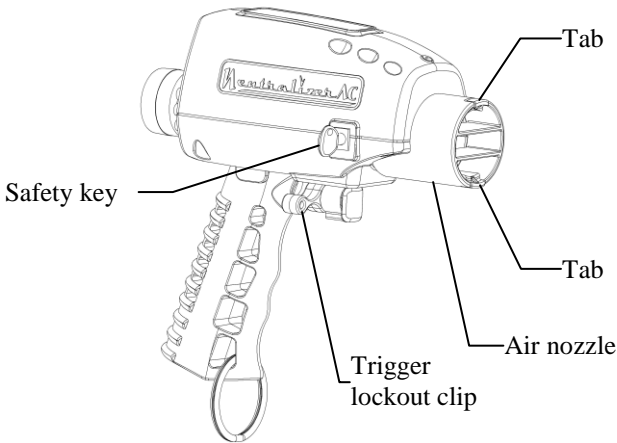

1. Turn off the compressed air.
2. **CAUTION:** To avoid shock hazard insert the safety key into the battery jack and attach the trigger lockout clip behind the trigger.
3. Carefully squeeze tabs together and slide the air nozzle off of the Neutralizer® AC Ionizing Blow Gun.
4. Using a pair of tweezers or pliers remove emitter pin from the pin holder, then through the outlet hole of the ionizer. Dispose of the emitter pin.

CAUTION: do not bend the pin holder.



2937 Alt Boulevard / PO Box 310 / Grand Island, NY 14072-0310
PHONE 716 773 7634 / FAX 716 773 7744 / EMAIL sales@nrdinc.com / WEB www.nrdinc.com

Installation / Maintenance

Neutralizer[®] AC

Emitter Pin Replacement

Model 6500

Replace the emitter pin as follows: (cont'd)

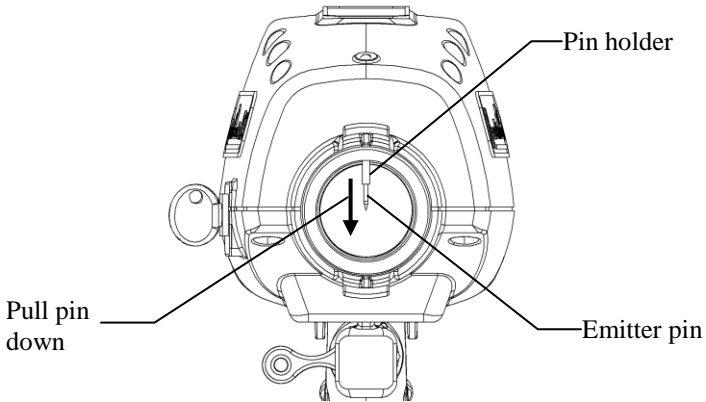

5. Insert the new emitter pin using the tweezers or pliers. Be sure to push the emitter pin in as far as it will go.

CAUTION: do not bend the pin holder.

6. Carefully slide the air nozzle back over the tabs and snap it into place.
7. Remove the safety key and the trigger lockout clip. (Do not discard, save to use later)
8. Turn on the compressed air.



2937 Alt Boulevard / PO Box 310 / Grand Island, NY 14072-0310
PHONE 716 773 7634 / FAX 716 773 7744 / EMAIL sales@nrdinc.com / WEB www.nrdinc.com